



YFG255 Rethermalizer

Service & Parts Manual



Frymaster, a member of the Commercial Food Equipment Service Association, recommends using CFESA Certified Technicians.

www.frymaster.com

24-Hour Service Hotline
1-800-551-8633

Email: service@frymaster.com

SEPTMBER 2011
* 8196900 *

Please read all sections of this manual and retain for future reference.

This product has been certified as commercial cooking equipment and MUST be installed by professional personnel as specified. Installation, maintenance and repairs should be performed by your Frymaster Factory Authorized Servicer (FAS).

 DANGER

Do not store or use gasoline or other flammable vapors and liquids in the vicinity of this or any other cooking appliance.

 DANGER

Instructions explaining procedures to be followed MUST be posted in a prominent location in the event the operator detects a gas leak. This information can be obtained from the local gas company or gas supplier.

 DANGER

Safe and satisfactory operation of your equipment depends on proper installation. Installation MUST conform with local codes, or in absence of local codes, with the National Fuel Gas Code, ANSI Z223.1; The Natural Gas Installation Code, CAN/CGA-B149.1; The Propane Installation Code, CAN/CGA-B149.2; or The latest edition of the National Electric Code, N.F.P.A. 70.

NOTICE

If, during the warranty period, the customer uses a part for this Manitowoc Food Service equipment other than an unmodified new or recycled part purchased directly from Frymaster or any of its authorized servicers, and/or the part being used is modified from its original configuration, this warranty will be void. Further, Frymaster and its affiliates will not be liable for any claims, damages or expenses incurred by the customer which arise directly or indirectly, in whole or in part, due to the installation of any modified part and/or part received from an unauthorized servicer.

 DANGER

The front ledge of the rethermalizer is not a step. Do not stand on the rethermalizer. Serious injury can result from slips or contact with the hot water.

 WARNING

Drawings and photos used in this manual are intended to illustrate operational, cleaning and technical procedures and may not conform to on-site management operational procedures.

 WARNING

No structural material on the rethermalizer should be altered or removed to accommodate placement of the rethermalizer under a hood. Questions? Call the Frymaster Service Hotline at 1-800-551-8633.

NOTICE

This equipment is to be installed in compliance with the basic plumbing code of The Building Officials and Code Administrators International, Inc. (BOCA) and the Food Service Sanitation Manual of the Food and Drug Administration.

NOTICE

The Commonwealth of Massachusetts requires any and all gas products to be installed by a licensed plumber or pipe fitter.

CONTROLLERS

FCC

This device complies with Part 15 of the FCC rules. Operation is subject to the following two conditions: 1) This device may not cause harmful interference, and 2) This device must accept any interference received, including interference that may cause undesired operation. While this device is a verified Class A device, it has been shown to meet the Class B limits.

CANADA

This digital apparatus does not exceed the Class A or B limits for radio noise emissions as set out by the ICES-003 standard of the Canadian Department of Communications.

Cet appareil numérique n'émet pas de bruits radioélectriques dépassant les limites de classe A et B prescrites dans la norme NMB-003 édictée par le Ministre des Communications du Canada.

DANGER

THIS PRODUCT CONTAINS CHEMICALS KNOWN TO THE STATE OF CALIFORNIA TO CAUSE CANCER AND/OR BIRTH DEFECTS OR OTHER REPRODUCTIVE HARM.

Operation, installation, and servicing of this product could expose you to airborne particles of glasswool or ceramic fibers, crystalline silica, and/or carbon monoxide. Inhalation of airborne particles of glasswool or ceramic fibers is known to the State of California to cause cancer. Inhalation of carbon monoxide is known to the State of California to cause birth defects or other reproductive harm.

WARNING

Do not bang rethermalizer baskets or other utensils on the rethermalizer's joiner strip. The strip is present to seal the joint between the cookpot vessels. Banging rethermalizer baskets on the strip will distort the strip, adversely affecting its fit. It is designed for a tight fit and should only be removed for cleaning.

DANGER

Improper installation, adjustment, maintenance or service, and unauthorized alterations or modifications can cause property damage, injury, or death. Read the installation, operating and service instructions thoroughly before installing or servicing this equipment. Only qualified service personnel may convert this appliance to use a gas other than that for which it was originally configured.

DANGER

Adequate means must be provided to limit the movement of this appliance without depending upon the gas line connection or transmitting stress to the electrical conduit. Single rethermalizers equipped with legs must be stabilized by installing anchor straps. All rethermalizers equipped with casters must be stabilized by installing restraining chains. If a flexible gas line is used, an additional restraining cable must be connected at all times when the rethermalizer is in use.



**YFG255 Series Rethermalizers
Service & Parts Manual**

TABLE OF CONTENTS

	Page #
1. SERVICE PROCEDURES	1-1
1.1 Functional Description	1-1
1.2 Accessing Fryers for Service	1-3
1.3 Cleaning the Gas Valve Vent Tube (if applicable)	1-3
1.4 Adjusting Burner Manifold Gas Pressure	1-3
1.5 Replacing Rethermalizer Components	1-4
1.6 Troubleshooting and Problem Isolation	1-13
1.7 Troubleshooting Guides	1-18
1.8 Probe Resistance Chart	1-20
1.9 Wiring Diagram	1-21
2. PARTS LIST	2-1
2.1 YFG255 Cabinet and Related Components	2-1
2.2 Cookpot Assemblies and Components	2-3
2.3 Transformer Boxes and Control Frame Assemblies	2-4
2.4 Harnesses	2-5
2.5 Plumbing, Incoming Water	2-6
2.6 Plumbing, Drain	2-7
2.7 Plumbing, Gas Manifold	2-8
2.8 Fasteners	2-9

YFG255 SERIES GAS RETHERMALIZERS

CHAPTER 1: SERVICE PROCEDURES

1.1 Functional Description

YFG255 Series gas rethermalizers contain a welded stainless steel cookpot that is heated by gas flames diffused evenly through tubes built into the cookpot.

Flames originate from orifices in a burner manifold positioned beneath the burners. The burners are positioned in the tube openings, at the front of the cookpot. The diameter of the orifices differs for natural (CE:G20/G25) and LP (CE:G31) gas as indicated in the accompanying table.

NON-CE (Altitudes of 2000 feet or less)							
MODEL	INPUT (BTU)	GAS TYPE	ORIFICE MM (INCH)	ORIFICE PART NO.	QTY	EQUIPMENT PRESSURE	
						MBAR	INCH W.C.
YFG255	90	NAT	2.38(#42)	810-2926	2	10	4
		LP	1.51(#53)	810-2941	2	27.5	11
CE ONLY (Altitudes of 2000 feet or less)							
MODEL	INPUT (kW)	GAS TYPE	ORIFICE MM (INCH)	ORIFICE PART NO.	QTY/ COLOR	EQUIPMENT PRESSURE	
						MBAR	INCH W.C.
YFG255	26.4	G20	2,38	810-2926	2/BLUE	10,0	4,0
		G25	2,38	810-2926	2/BLUE	15,0	6,0
		G31	1,51	810-2941	2/RED	27,0	10,8

An electromechanical gas valve regulates gas flow to the manifold. YFG255 Series gas rethermalizers are equipped with a 24-volt valve system with an electronic ignition system.

Electronic Ignition Configuration

An ignition module connected to an ignitor assembly controls ignition. The ignition module performs three important functions: it provides an ignition spark, supplies voltage to the gas valve, and proofs the pilot flame.

The module contains a 60-second time delay circuit and a coil that activates the gas valve. The ignitor assembly consists of a spark plug, a pilot, and a flame sensor element.

At start-up the power switch is placed in the "ON" position, supplying 12 VDC to the heat control circuitry in the controller. Current is supplied to the other leg of the heat relay coil which then closes an electronic switch in the 24 VAC circuit to provide current to the ignition module.

Circuitry in the ignition module sends 24 VAC current to the gas valve via a normally closed float switch. Simultaneously, the module causes the ignitor to spark for up to 60 seconds to light the pilot flame. A flame sensor verifies that the pilot is lit by measuring the flow of microamps through the flame. If the pilot does not light (or is extinguished), current to the ignition module is interrupted, preventing the main valve from opening, and the ignition module "locks out" until the power switch is turned "OFF", then back "ON".

YFG255 SERIES GAS RETHERMALIZERS

CHAPTER 1: SERVICE PROCEDURES

A temperature probe monitors the temperature in the cookpot. When the programmed setpoint temperature is reached, resistance in the probe causes the heat cycle circuitry in the controller to interrupt current flow through the heat relay. This in turn interrupts the 24 VAC current to the ignition module, resulting in closure of the gas valve.

Control Options

YFG255 Series gas rethermalizers are equipped with a factory preset temperature controller. These are unique in that the components are wired directly to the controller and do not require an interface board.

Temperature Probe

YFG255 rethermalizers are equipped with a temperature probe with resistance values that correspond directly with the temperature. That is, as the temperature rises, so does resistance. See the resistance table on page 1-20. Circuitry in the controller monitors the probe resistance and controls burner firing when the resistance exceeds or falls below programmed temperatures (setpoints).

YFG255 SERIES GAS RETHERMALIZERS

CHAPTER 1: SERVICE PROCEDURES

1.2 Accessing Rethermalizers for Servicing

 **DANGER**

Moving a rethermalizer filled with water may cause spilling or splattering of the hot liquid. Follow the draining instructions included with the rethermalizer before attempting to relocate a rethermalizer for servicing.

1. Shut off the gas supply to the unit. Unplug the power cords. Remove any attached restraining devices.
2. Disconnect the unit from the gas supply.
3. Relocate the rethermalizer for service accessibility.
4. After servicing is complete, reconnect the unit to the gas supply, reattach restraining devices, and plug in the electrical cords.

1.3 Cleaning the Gas Valve Vent Tube (if applicable)

1. Set the rethermalizer power switch and the gas valve to the "OFF" position.
2. Carefully unscrew the vent tube from the gas valve. **NOTE:** The vent tube may be straightened for ease in removal.
3. Pass a piece of ordinary binding wire (.052 inch diameter) through the tube to remove any obstruction. Remove the wire and blow through the tube to ensure it is clear.
4. Reinstall tube and bend so that the opening is pointing downward.

1.4 Adjusting Burner Manifold Gas Pressure

 **WARNING**

This task should be performed by qualified service personnel only.

1. Ensure that the gas valve knob is in the "OFF" position.
2. Remove the pressure tap plug from the gas valve (see arrows in photos on the following page for location).

YFG255 SERIES GAS RETHERMALIZERS

CHAPTER 1: SERVICE PROCEDURES

1.4 Adjusting Burner Manifold Gas Pressure (cont.)

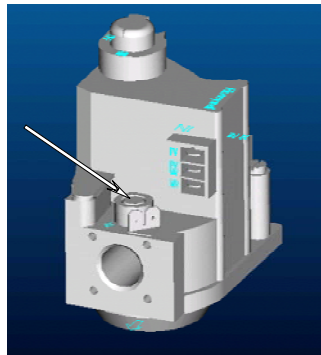

Non-CE Electronic Ignition Valve

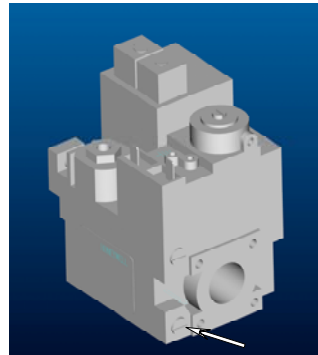

CE Pilot Ignition Valve

3. Insert the fitting for a gas pressure-measuring device into the pressure tap hole.
4. Place the gas valve in the "ON" position then place the rethermalizer power switch in the "ON" position. When the burner lights and continues to burn, note gas pressure reading for correct pressure in accordance with the table on page 1-1.
5. To adjust burner gas pressure, remove the cap from the gas valve regulator and adjust to correct pressure.
6. Place the rethermalizer power switch and the gas valve in the "OFF" position. Remove the pressure-measuring device fitting from the pressure tap hole and reinstall the pressure tap plug.

1.5 Replacing Rethermalizer Components

1.5.1 Replacing the Controller or Solid State Relays

1. Disconnect the rethermalizer from the electrical supply.
2. Open the cabinet doors and unscrew the three controller panel screws located beneath the bezel. The controller panel will drop down and will rest on the open doors.
3. Mark the wires for reassembly and using a small screwdriver loosen and remove the wires from the rear of the controller. If replacing the relays disconnect the wires and replace the faulty relay.

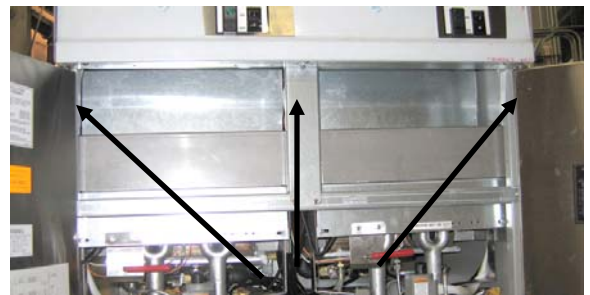

Remove the three bezel screws.

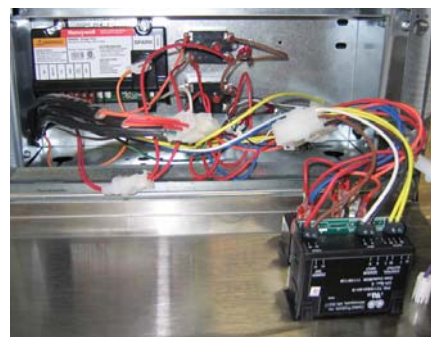

Mark wires for reassembly.

YFG255 SERIES GAS RETHERMALIZERS

CHAPTER 1: SERVICE PROCEDURES

1.5.1 Replacing the Controller or Solid State Relays cont.

4. Remove the controller from the bezel.
5. Reverse the procedure to install a new controller.

1.5.2 Replacing the Temperature Probe

1. Disconnect the rethermalizer from the electrical supply.
2. Drain the water from the cookpot. Allow the cookpot to cool completely before proceeding.
3. Remove the rethermalizer door for easier access to the temperature probe. Lift door up, disengage rod from lower door bracket, and then remove door.



Remove door for easier access to temperature probe.

4. Gain access to probe wires in control box behind controller using the steps in the previous section 1.5.1.
5. Disconnect the probe harness connector (see right).

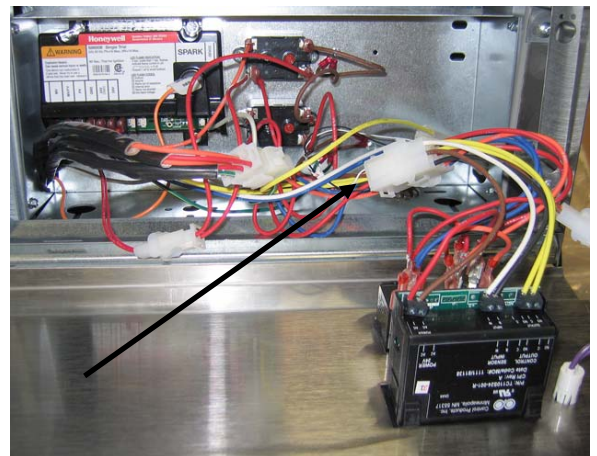

Unplug connector.

6. Use a pin pusher to remove probe wires from the plug.

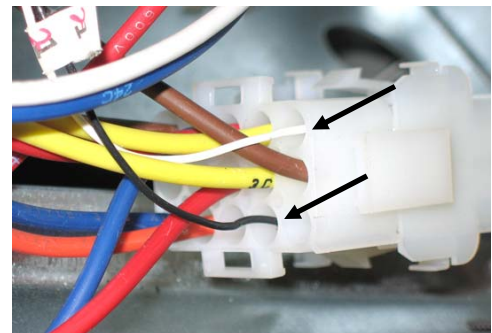

Remove probe wires.

YFG255 SERIES GAS RETHERMALIZERS

CHAPTER 1: SERVICE PROCEDURES

1.5.2 Replacing the Temperature Probe (cont.)

7. Loosen and unscrew completely the compression nut, then the pass-through nut from the cookpot. Proceed to the next step before removing probe from cookpot.

Note: The temperature probe can be removed through the top of the cookpot as follows: Ensure the probe wires have been removed from the connector (step 6). Remove the harness insulation. The probe can be pulled through the cookpot from the top (complete step 7 in this section, prior to removing probe).

8. Carefully remove the probe from the cookpot.
9. Reverse steps for installation of new probe.

IMPORTANT: When installing new probe, ensure probe is positioned properly with the mounting hardware installed prior to tightening the compression nut. **Once tightened, the probe cannot be repositioned.**

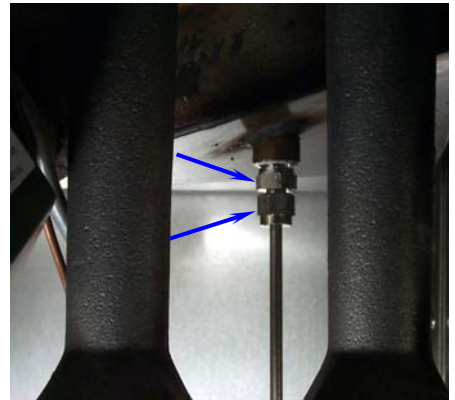

Loosen and unscrew completely the compression nut (bottom arrow) first. Loosen the pass-through nut (top arrow).



Remove the temperature probe.

YFG255 SERIES GAS RETHERMALIZERS CHAPTER 1: SERVICE PROCEDURES

1.5.3 Replacing Float Switches

1. Disconnect the rethermalizer from the electrical power supply.
2. Drain the water from the cookpot. Allow the cookpot to cool completely before proceeding.
3. Unplug the low float switch connector from behind the controller (See section 1.5.1 for instructions on removing the bezel.), or the high level float from the rear of the rethermalizer near the fresh water connection.
4. Remove the clip and float from float switch shaft.
5. Remove the rethermalizer back to gain access to the high level float compression nut. Removal of a burner may be necessary to access the low level float compression nut.
6. Loosen and completely unscrew the compression nut from the cookpot.
7. Carefully pull the float switch shaft out of the cookpot.
8. Reverse the above steps for float switch installation.

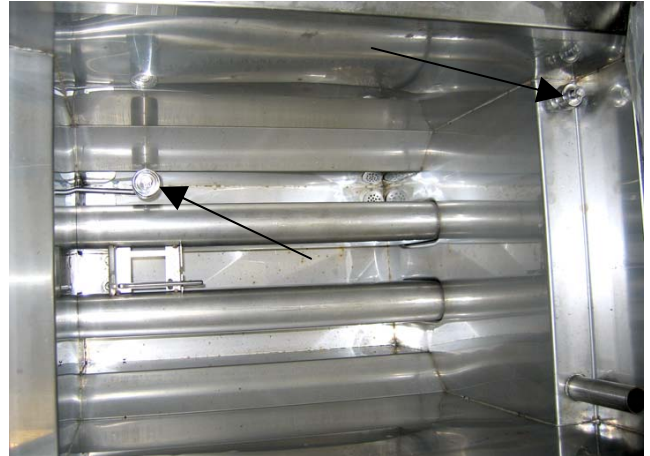

The lower float switch (left), the high level float (right).

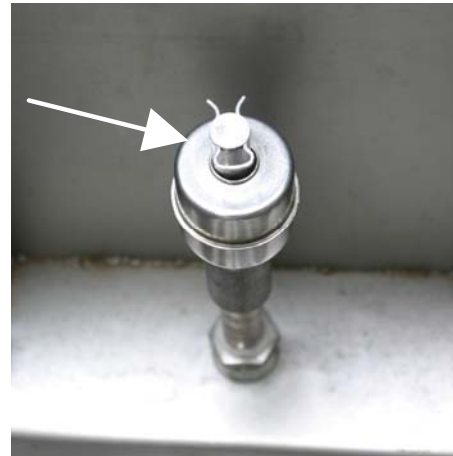

Remove the clip

1.5.4 Replacing the Gas Valve



DANGER

Drain the cookpot or remove the handle from the drain valve before proceeding further.

1. Disconnect rethermalizer from electrical and gas supplies.
2. Disconnect the wires from the gas valve terminal block, marking each wire to facilitate reconnections.
3. Remove the pilot gas line fitting from the gas valve.

YFG255 SERIES GAS RETHERMALIZERS

CHAPTER 1: SERVICE PROCEDURES

4. Remove the pipe union collars to the left and right of the gas valve and remove the valve.
5. Remove the pipefitting from the old gas valve and install on the replacement valve, using Loctite™ PST567 or equivalent pipe thread sealant on threads. Do not apply sealant to the first two pipe threads. Doing so will clog and damage the gas valve.
6. Reverse steps 1-4 to install the replacement gas valve.

1.5.5 Replacing the Pilot Assembly

1. Remove the pilot tubing from the bottom of the pilot assembly.
2. Disconnect the ignition cable and the sense wire.
3. Remove the two pilot mounting screws from the pilot mounting-bracket and remove the pilot.
4. Reverse the procedure to replace the pilot assembly.

1.5.6 Replacing the Cookpot

1. Ensure controller and all power switches are off. Drain water from all cookpots prior to moving rethermalizer.



Hot water will cause severe burns. Never attempt to move this appliance when filled with hot water or to transfer hot water from one container to another.

2. Turn gas valve off, then turn gas off at supply valve or meter. Disconnect supply line from gas manifold at rear of rethermalizer.

NOTE: If restraints are installed on the rethermalizer, disconnect restraints prior to disconnecting the gas supply line.

3. Unplug rethermalizer from electrical supply source.
4. Remove rethermalizer door for access to cabinetry components. Lift door up, disengage rod from lower door bracket, remove and set door aside.

YFG255 SERIES GAS RETHERMALIZERS CHAPTER 1: SERVICE PROCEDURES

1.5.6 Replacing the Cookpot (cont.)

5. Remove upper cookpot cover and bracket.
6. Carefully pry up and remove capping strip.

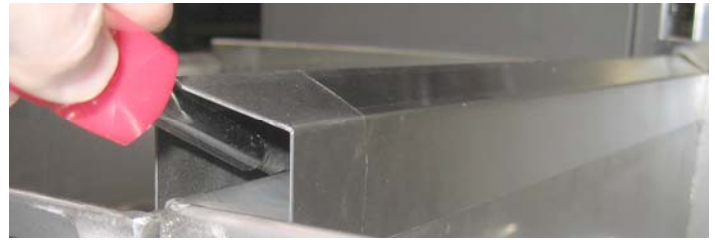

Removing capping strip.

7. Locate all screws securing back panels. Screw location/orientation will vary according to rethermalizer model.

8. Remove back panels on rethermalizer. Retain screws for re-assembly.

9. Remove screw securing back-panel brace to flue cap. Support brace with hand while removing screw to prevent brace from falling away. Remove brace and set aside for reassembly.

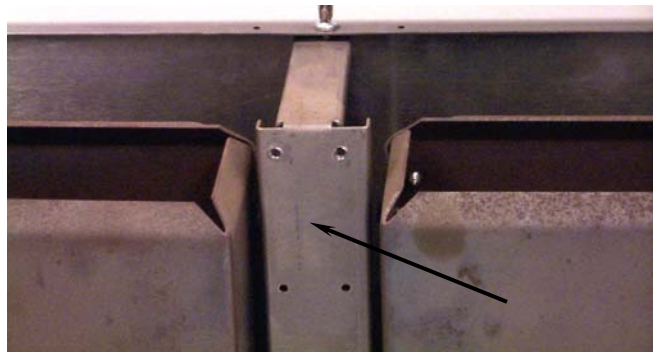

Removing back panel to flue cap brace (arrow).

10. Remove screws securing flue-cap braces to cookpot (a nut-driver with an extension or long screwdriver is required). Use care not to drop the screws into the flues. If this happens, the screws can be retrieved when the flue is removed (Step 12). Use a screwdriver or similar tool to free flue cap from cookpots. Remove flue cap by lifting up and off of rethermalizer.



Removing flue cap.

11. Remove gas manifold pipe for access to gas manifold shield by disconnecting at the unions. Ensure gas supply is shut off and supply line is disconnected prior to removing. Set gas manifold aside. Remove screws securing gas manifold shield. Remove shield to access water-return plumbing components connected to the cookpots.



Removing gas manifold shield.

YFG255 SERIES GAS RETHERMALIZERS CHAPTER 1: SERVICE PROCEDURES

1.5.6 Replacing the Cookpot (cont.)

12. Remove four bolts securing flue to the cookpot being removed. Remove the flue by sliding back and away until clear of cookpot. Retrieve any screws dropped into the flue during removal of the flue cap to cookpot bracket.



Removing bolts (arrows) securing flue to cookpot.

13. Remove the burner shield. Loosen burner bolts (two per burner) that secure burners to the burner support rail.

NOTE: On most rethermalizers, do not remove bolts from burners.

14. Lift each burner upward to clear the orifice, then slant the top of the burner inward to clear the burner-brace keyholes.

Loosening burner bolts prior to burner removal.



Removing burners from rethermalizer.



YFG255 SERIES GAS RETHERMALIZERS

CHAPTER 1: SERVICE PROCEDURES

1.5.6 Replacing the Cookpot (cont.)

15. Remove screw(s) securing the electronic or standing pilot bracket to the cookpot bracket. Reposition ignitor assembly down and away from cookpot. Use care not to bend, kink or damage the electronic ignition lines and wiring.



Removing electronic/standing pilot assembly.

16. Remove nut from drain valve linkage, then disconnect actuator rod from drain valve actuator.

17. Remove the temperature probe from cookpot. (see Section 1.5.2, Replacing Temperature Probe for specific instructions.

18. Disconnect the fresh water line from the cookpot.

19. The rethermalizer is equipped with float-valve switches, mark the wires and terminals, then disconnect wires from the switch. Secure the wires to prevent damage when cookpot is removed.



Removing bolts (arrows) from burner manifold support brackets (both sides). Leave the burner manifold in place after removing bolts.

20. Remove bolts from brackets securing burner manifold to cookpot. Leave the manifold in place.

21. Using a sharp knife or box-cutter, cut the silicon seal between and in front of the two cookpots. Use care not to scratch stainless steel surfaces.

22. Remove cookpot from rethermalizer by lifting up and out.



Lift cookpot from rethermalizer.

23. Position the cookpot upside down on a suitable work surface.



Cut cookpot seal prior to cookpot removal.

24. Record position of the valve stem in relation to the cookpot prior to removing the drain valve. Using a suitable wrench, remove the drain valve from the cookpot. Use Loctite PST567 sealant when installing drain valve on replacement cookpot.

25. Reverse the above steps to install replacement cookpot.

YFG255 SERIES GAS RETHERMALIZERS

CHAPTER 1: SERVICE PROCEDURES

1.5.7 Annotated Cookpot Bottom

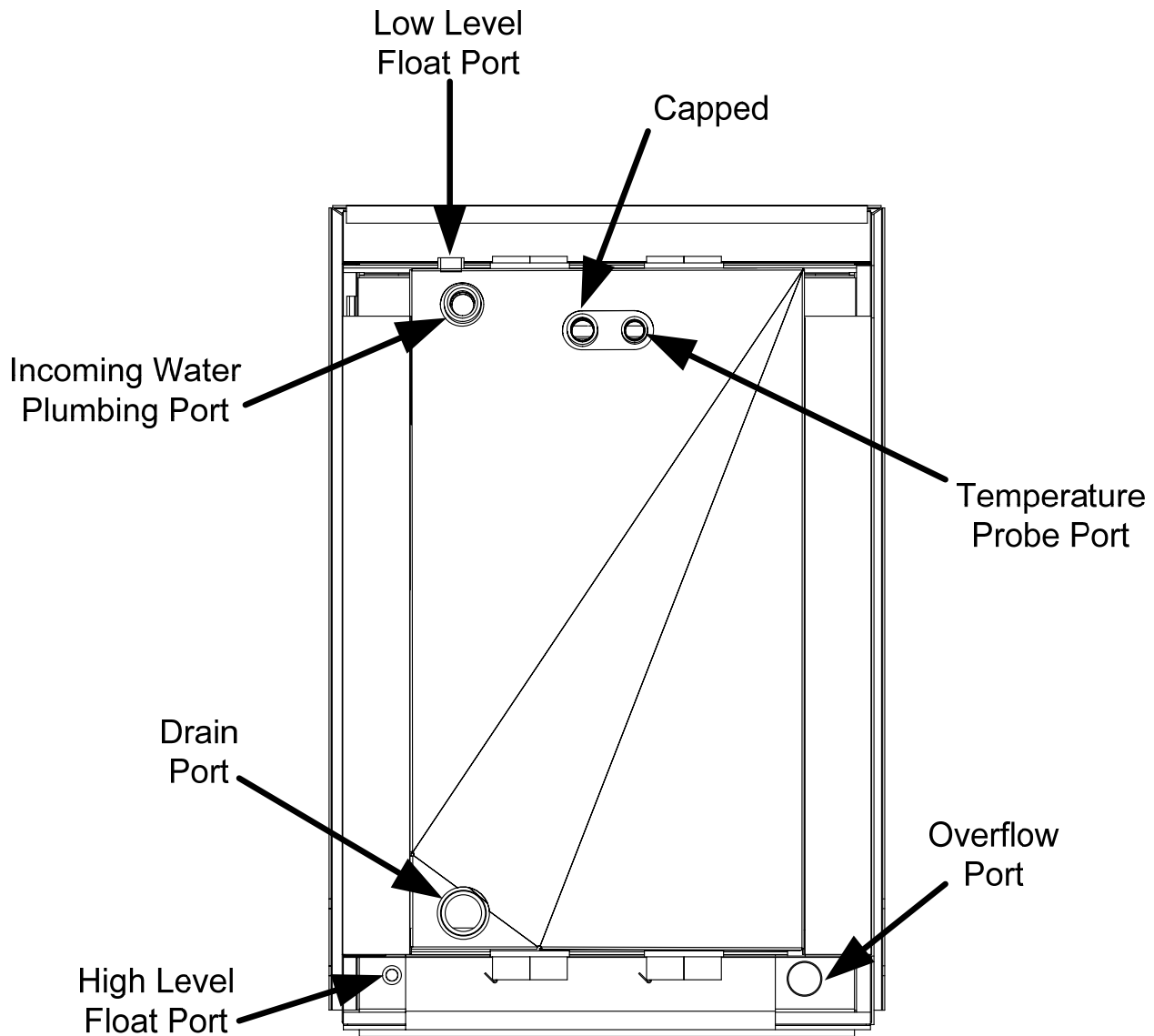

View from bottom of cookpot.

YFG255 SERIES GAS RETHERMALIZERS

CHAPTER 1: SERVICE PROCEDURES

1.6 Troubleshooting and Problem Isolation

This section is intended to provide technicians with a general knowledge of the broad problem categories associated with this equipment, and the probable causes of each. With this knowledge, the technician should be able to isolate and correct any problem encountered.

Problems you are likely to encounter can be grouped into seven broad categories:

1. Ignition failures
2. Improper burner functioning
3. Improper temperature control
4. Controller-related problems
5. Leakage

The probable causes of each category are discussed in the following sections. Troubleshooting guides are included in Section 1.7 to assist in identifying some of the more common problems.

1.6.1 Ignition Failures

Ignition failure occurs when the ignition module fails to sense a flame within the 60-second time delay period and locks out. Turn the rethermalizer off, locate and fix the problem, then turn rethermalizer back on to clear the module lock.

There are three primary reasons for ignition failure, listed in order of probability:

1. Problems related to the gas and/or electrical power supplies.
2. Problems related to the electronic circuits.
3. Problems related to the gas valve.

Problems Related to the Gas and/or Electrical Power Supplies

The main indicators of this are that an entire battery of rethermalizers fails to light. Verify that the quick disconnect hose is properly connected, the rethermalizer is connected to power, the main gas supply valve is open, and the circuit breaker for the rethermalizer electrical supply is not tripped.

YFG255 SERIES GAS RETHERMALIZERS

CHAPTER 1: SERVICE PROCEDURES

1.6.1 Ignition Failures (cont.)

Problems Related to the Electronic Circuits

If gas and electrical power are supplied to the rethermalizer, the next most likely cause of ignition failure is a problem in the 24 VAC circuit. First verify that the float switch valve is fully closed and not sticking. (The float switch must be closed for power to reach the gas valve. Often, a starch build up will cause the float switch to stick, impeding movement up and down the shaft. Simple cleaning of the shaft will fix the problem.) If the float switch is fully closed, refer to the troubleshooting guides in this chapter.

Problems Related to the Gas Valve

If the problem is not in the 24 VAC circuit or pilot system, it is most likely in the gas valve itself, but before replacing the gas valve refer to the troubleshooting guides in this chapter.

1.6.2 Improper Burner Functioning

With problems in this category, the burner ignites but exhibits abnormal characteristics such as "popping", incomplete lighting of burner, fluctuating flame intensity, and flames "rolling" out of the rethermalizer.

"Popping" indicates delayed ignition. In this condition, the main gas valve is opening but the burner is not immediately lighting. When ignition does take place, the excess gas "explodes" into flame, rather than smoothly igniting.

The primary causes of popping are:

- Incorrect or fluctuating gas pressure
- Misdirected or weak pilot flame
- Clogged burner orifices
- Clogged burners
- Inadequate make-up air
- Heat damage to the controller or ignition module
- An out-of-adjustment ignitor or broken ignition wire
- A defective ignition module

YFG255 SERIES GAS RETHERMALIZERS

CHAPTER 1: SERVICE PROCEDURES

1.6.2 Improper Burner Functioning (cont.)

If popping occurs only during peak operating hours, the problem may be incorrect or fluctuating gas pressure. Verify that the incoming gas pressure (pressure to the gas valve) is in accordance with the appropriate CE or Non-CE requirements listed in the Installation and Operation manual that came with the rethermalizer, and that the pressure remains constant throughout all hours of usage. Refer to Adjusting Burner Manifold Pressure in Section 1.4 if burner manifold pressure is suspected of being incorrect.

If popping is consistent during all hours of operation, verify that the pilot is properly positioned above the burner orifice and that the pilot pressure is correct. Correct pilot pressure is indicated by a flame 1 to 1½" long. Also verify that ignitor is properly adjusted (electrode tip 1/8" from pilot hood corner).

Clogged burners and/or burner orifices are also likely causes of delayed ignition. Clogged burners are indicated by uneven flame or partial flame on the burner face. Clogged orifices are indicated by no flame.

Another cause of popping is an insufficient air supply or drafts that are blowing the pilot flame away from the burner. Check for "negative pressure" conditions in the kitchen area. If air is flowing into the kitchen area, this indicates that more air is being exhausted than is being replenished and the burners may be starved for air.

If the rethermalizers gas and air supplies are okay, the problem most likely is with one of the electrical components. Examine the ignition module for signs of melting/distortion and/or discoloration due to excessive heat build-up in the rethermalizer. (This condition usually indicates improper flue performance.). Also, examine the controller for the same conditions. A melted or distorted ignition module is automatically suspect and should be replaced, but unless the condition causing excessive heat in the rethermalizer is corrected, the problem is likely to recur.

Next, ensure the ignition wire is tightly connected at both ends and examine it for obvious signs of damage. Again, if damage is due to excessive heat in the rethermalizer, that problem must also be corrected.

Check for proper operation by disconnecting the wire from the ignitor, inserting the tip of a screwdriver into the terminal, and holding it near the frame of the rethermalizer as the power switch is placed in the "ON" position. A strong, blue spark should be generated for at least 60 seconds.



MAKE SURE YOU ARE HOLDING THE INSULATED HANDLE OF THE SCREWDRIVER AND NOT THE BLADE. THE SPARKING CHARGE IS APPROXIMATELY 25,000 VOLTS.

Ensure the gap setting of the ignitor is correct (electrode tip 1/8" from pilot hood corner).

Burners lighting on the left side only may be caused by a trailing pilot problem or improper burner manifold pressure.

YFG255 SERIES GAS RETHERMALIZERS

CHAPTER 1: SERVICE PROCEDURES

Fluctuating flame intensity is normally caused by either improper or fluctuating incoming gas pressure, but may also be the result of variations in the kitchen atmosphere. Verify incoming gas pressure in the same way as for "popping", discussed in the preceding paragraphs. Variations in the kitchen atmosphere are usually caused by air conditioning and/or ventilation systems starting and stopping during the day. As air conditioning/ventilation systems start and stop, the pressure in the kitchen may change from positive or neutral to negative, or vice versa. Changes in airflow patterns may affect flame intensity.

Flames "rolling" out of the rethermalizer are usually an indication of negative pressure in the kitchen. Air is being sucked out of the rethermalizer enclosure and the flames are literally following the air. If negative pressure is not the cause, check for high burner-manifold gas pressure in accordance with the procedures in Section 1.4. An obstructed flue, which prevents the rethermalizer from properly exhausting, may also be the cause.

Excessively noisy burners, especially with *flames visible above the flue opening*, may indicate that the burner gas pressure is too high, the tube diffusers are defective or burned out, or it may simply be that the gas valve vent-tube is blocked (if applicable). If the gas pressure is correct, the tube diffusers are intact and in good condition, and the vent-tube is unobstructed (if applicable), the gas valve regulator is probably defective.

1.6.3 Improper Temperature Control

Temperature control is a function of several interrelated components, each of which must operate correctly. The principal component is the temperature probe. Depending upon the specific configuration of the rethermalizer, other components may include the controller itself, the temperature probe, and the ignition module.

Improper temperature control problems can be failure to control at setpoint.

Failure to Control at Setpoint

The problem may be with the temperature probe or the controller. Refer to the troubleshooting guides in this chapter.

YFG255 SERIES GAS RETHERMALIZERS

CHAPTER 1: SERVICE PROCEDURES

1.6.4 Leakage

Cookpot leaks are almost always due to an improperly sealed temperature probe, float switches and drain fittings. When installed or replaced, each of these components must be sealed with Loctite PST567 sealant or equivalent to prevent leakage. In very rare cases, a leak may develop along one of the welded edges of the cookpot, or where the tube is welded to the cookpot. When this occurs, the cookpot must be repaired or replaced.

If the sides or ends of the cookpot are coated with water minerals, the most likely cause is spillage over the top of the cookpot rather than leakage.

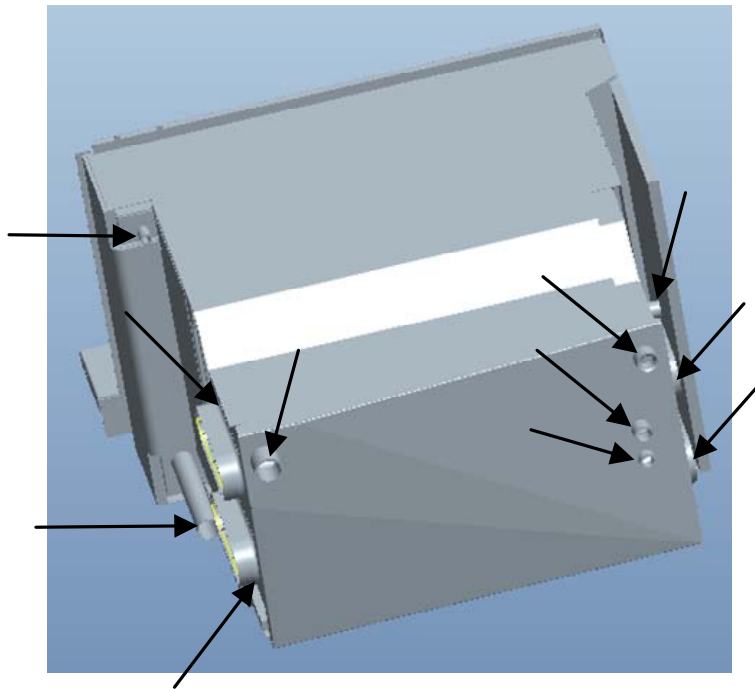

Cookpot locations (indicated by arrows) where potential leaks could occur.

**YFG255 SERIES GAS RETHERMALIZERS
CHAPTER 1: SERVICE PROCEDURES**

1.7 Troubleshooting Guides

The following troubleshooting guides are intended to assist service technicians in quickly isolating the probable causes of equipment malfunctions by following a logical, step-by-step process.

1.7.1 General Troubleshooting

PROBLEM	PROBABLE CAUSES	CORRECTIVE ACTION
No display on controller.	A. Rethermalizer is not turned on.	A. Press the ON/OFF switch to turn the controller on.
	B. No power to rethermalizer.	B. Verify that the rethermalizer is plugged in and that the circuit breaker is not tripped.
	C. Failed controller.	C. If available, substitute a controller known to be working for the suspect controller. If the rethermalizer functions correctly, order replacement from FAS.
The controller is illuminated, but there is no output to gas valve.	A. Float switch circuit is open.	A. Ensure float switch circuit is fully closed and is functioning. Make sure float is moving freely up and down and does not have a starch build up and that the shaft is not bent. Replace float switch if defective.
	B. Failed controller.	B. Replace the controller.
	C. Temperature probe defective.	C. Check temperature probe against standard Minco probe resistance chart on page 1-20. If found defective replace temperature probe. .
	D. Gas valve is suspect.	D. Go to "No burner flame" section.

**YFG255 SERIES GAS RETHERMALIZERS
CHAPTER 1: SERVICE PROCEDURES**

1.7.1 General Troubleshooting (cont.)

PROBLEM	PROBABLE CAUSES	CORRECTIVE ACTION
Heating indicator is on, but burners will not light.	A. Float switch stuck or defective.	A. Press the ON/OFF switch off. Clean float switch and make sure that the float switch is not bent and that the float moves freely up and down. Then press the ON/OFF switch on. Replace if defective.
	B. Gas valve is not turned on.	B. Turn the gas valve knob to the ON position.
	C. Manual gas shut off valve closed.	C. Verify that any in-line manual shut off valve is open. Verify that gas main cut off valve is open.
Heating indicator cycles on and off normally, but burners will not light.	A. Failed controller.	A. If available, substitute a controller known to be working for the suspect controller. If the rethermalizer functions correctly, order replacement from FAS.
Display shows a low temperature, and the rethermalizer appears to operate normally.	A. Defective probe.	A. Check temperature probe against standard Minco probe resistance chart on page 1-20. If defective replace temperature probe.
Unit won't fill with water.	A. Water solenoid defective.	A. Replace the defective solenoid valve.
	B. Float switch stuck or defective.	B. Press the ON/OFF switch off. Clean float switch and make sure that the float switch is not bent and that the float moves freely up and down. Then press the ON/OFF switch on. Replace if defective.
	C. Water supply turned off.	C. Check water supply valve. Use bypass switch to fill.
Fluctuating or erratic lighting of burner flame.	A. Incoming gas supply pressures are not within range [Natural- 6-14" W.C. (1.49-3.49 kPa); Propane- 11-14" W.C. (2.74-3.49 kPa)]	A. Inspect gas supply to rethermalizer. Repair and/or replace faulty components (defective supply shut-off valves, incorrect piping size, etc.)
	B. Air in gas supply lines (new installation).	B. Allow unit to cycle on and off for approximately 30 minutes to force air from gas manifold and lines.

**YFG255 SERIES GAS RETHERMALIZERS
CHAPTER 1: SERVICE PROCEDURES**

1.7.1 General Troubleshooting (cont.)

PROBLEM	PROBABLE CAUSES	CORRECTIVE ACTION
No burner flame.	A. Pilot does not stay lit.	A. Flame sensor possibly out of alignment. Realign flame sensor. Check flame sensor for loose wires.
	B. Pilot stays lit, and the flame sensor is working, but burners fail to light.	B. Inspect gas valve and replace if defective.
	C. Gas valve is known to be good, but there is not 24 VAC at the gas valve terminals.	C. Inspect temperature probe sensor (while still in cookpot) for damage. Replace if bent, dented or cracked. Inspect leads for fraying, burning, breaks and/or kinks. If found, remove and replace temperature probe.
	D. Continuity from ignition module block to gas valve is not "0".	D. Inspect wiring for breaks or shorts and repair if necessary.

1.8 Probe resistance Chart

Probe Resistance Chart		
<i>For use with rethermalizers using the Control Products Controller.</i>		
F°	OHMS	C°
50	1059	16
68	1070	18
77	1080	21
86	1091	24
104	1101	27
122	1112	29
140	1122	32
158	1133	35
176	1143	38
194	1154	41
212	1164	43

YFG255 SERIES GAS RETHERMALIZERS

CHAPTER 1: SERVICE PROCEDURES

1.9 Wiring Diagram

Note: The diagram in this section depict wiring as of the date of manual publication. It may not reflect design changes made to the equipment after publication. Refer to the wiring diagram affixed to the unit when actually troubleshooting this equipment.

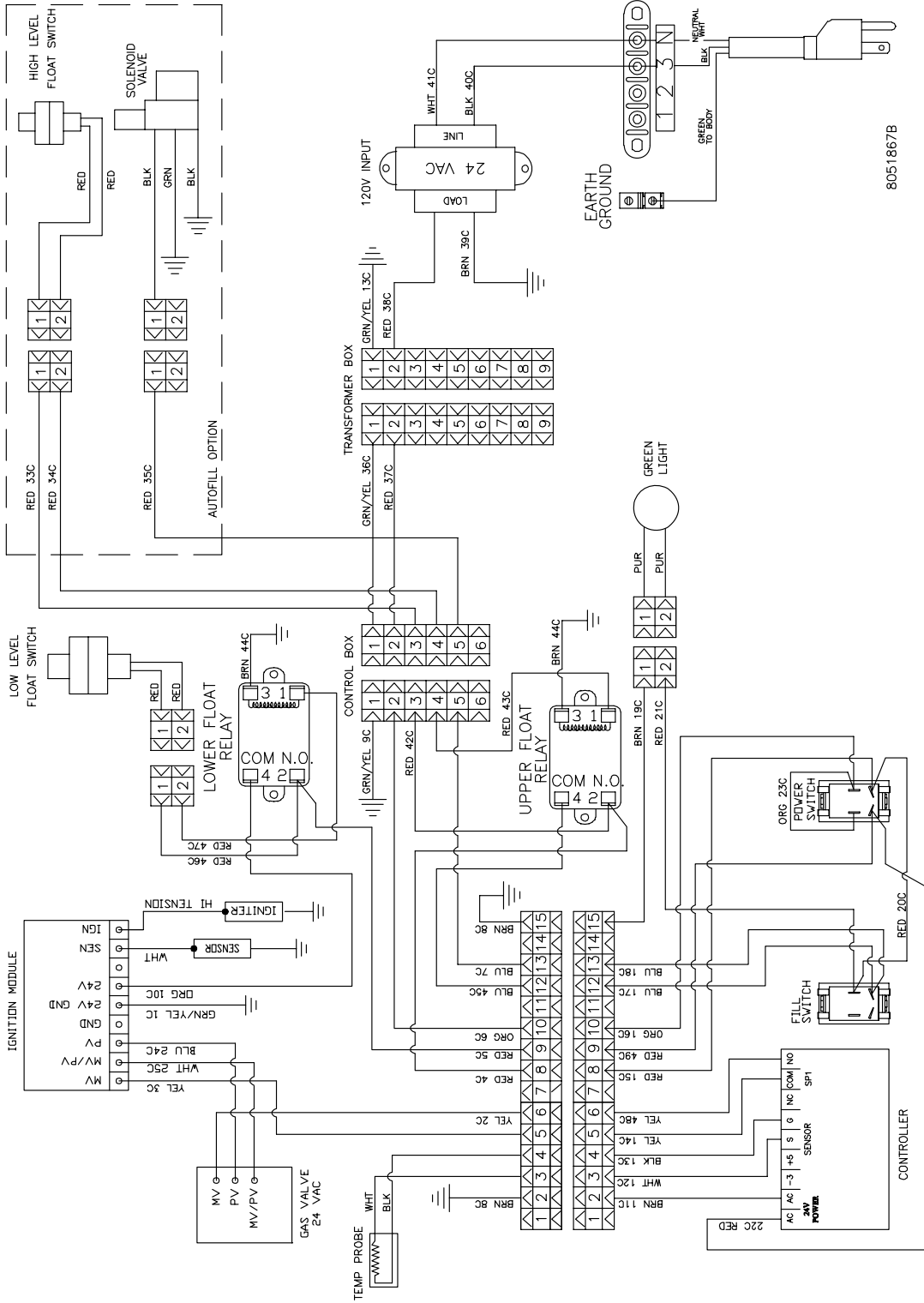

8051867B

YFG255 SERIES GAS RETHERMALIZERS

CHAPTER 2: PARTS LIST

2.1 YFG255 Cabinet and Related Components

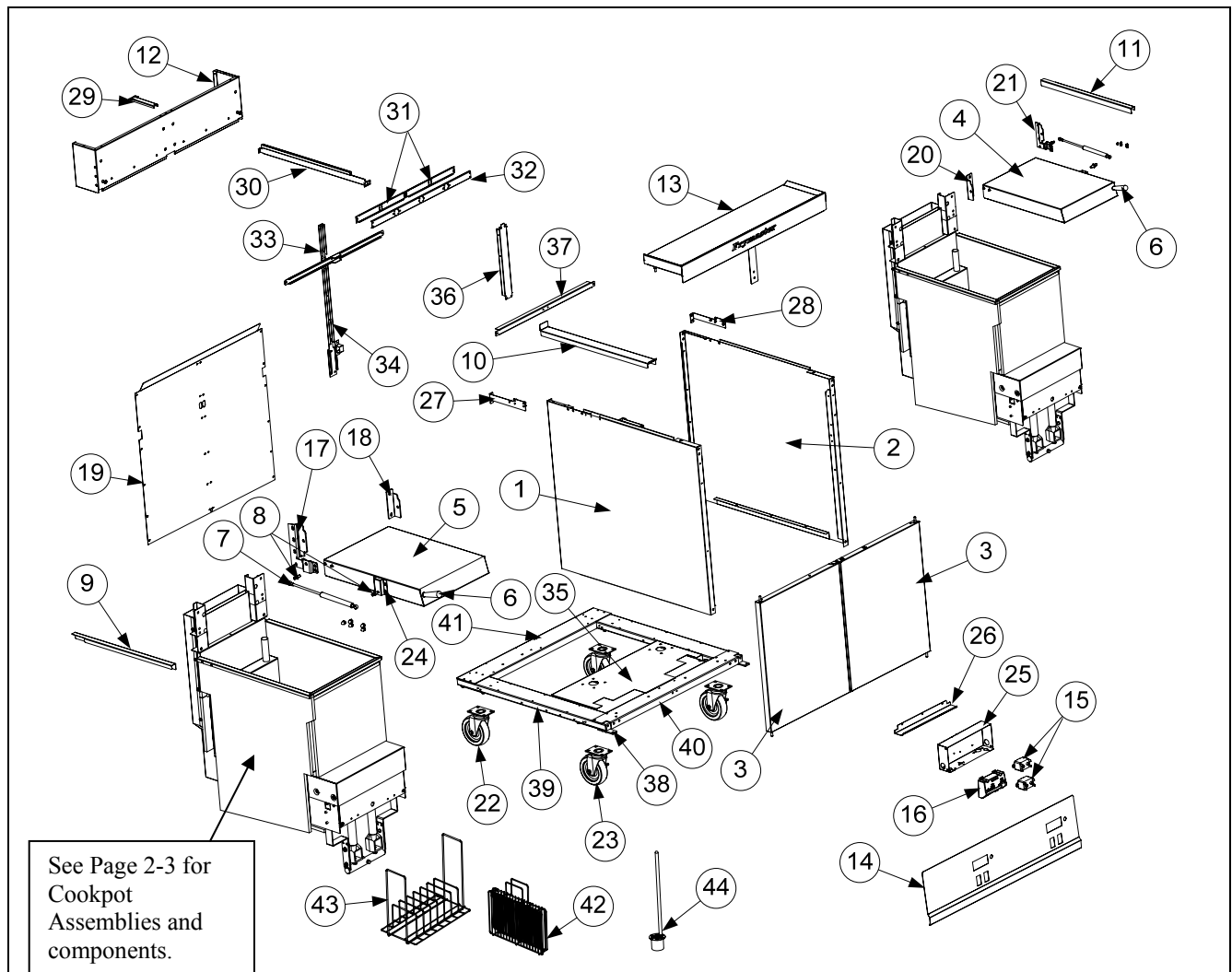

ITEM	PART #	COMPONENT
1	231-8755	Side Panel, Left Side
2	232-8755	Side Panel, Right Side
3	108-1803	Door Assembly
	106-4067	Pin Assembly
	230-5472	Handle, Door
	230-7249	Panel, Door
	230-7324	Panel, Door Liner
	810-0275	Spring, Door Hinge
*	810-2346	Magnet, Door
4	108-1111	Cover Assembly, Cookpot Right – includes item 6
5	108-1110	Cover Assembly, Cookpot Left – includes item 6
6	810-1374	Handle, Cover attaches with SS 3/8 Screw 809-0603
7	810-3879	Shock, Gas Spring
8	810-3881	Mount, Ball Stud 10MM

* Not illustrated

**YFG255 SERIES RETHERMALIZERS
CHAPTER 2: PARTS LIST**

2.1 YFG255 Cabinet and Related Components (cont.)

ITEM	PART #	COMPONENT
9	231-8098	Strip, Cookpot Rim Left
10	230-7244	Strip, Joiner
11	232-8098	Strip, Cookpot Rim Right
12	823-7899	Fluecap
13	823-7944	Topcap
14	230-8183	Fascia, Control Panel
15	807-0012	Relay, 18A 1/3 HP 24V Coil, Float
16	826-2117	Module, Ignition (Dean) Honeywell
*	106-3553SP	Cable, Ignition with Rajah Connector
17	231-6531	Hinge, Frypot Cover Outer Left
18	231-8049	Hinge, Cover Inner Left
19	220-8050	Back
20	232-8049	Hinge, Cover Inner Right
21	232-6531	Hinge, Frypot Cover Outer Right
22	826-1117	Caster, 5-inch w/o Brake Kit – includes washers and screws
23	826-1118	Caster, 5-inch with Brake Kit – includes washers and screws
24	230-8039	Pivot, Cover Front
25	220-7231	Box, Component
26	230-7383	Seal, Cookpot Cover
27	221-8051	Plate, Hinge Backing Left
28	222-8051	Plate, Hinge Backing Right
29	220-8081	Support, Fluecap
30	220-2773	Divider, Cookpot
31	220-7229	Brace, Back
32	220-7228	Brace, Horizontal Cabinet
33	220-7423	Post, Cabinet Rear
34	220-8126	Brace, Cabinet Lower
35	220-8186	Shield, Vapor
36	220-6033	Bracket, Component Box Support
37	220-7230	Brace, Rear Cabinet
38	230-7192	Hinge, Lower
39	220-2793	Channel, Base
40	220-7227	Channel, Front Base
41	220-7226	Channel, Rear Base
42	803-0325	Insert, Master Rack
43	803-0324	Master Rack 9 $\frac{1}{8}$ " x 13.00"
44	823-8148	Strainer
*	803-0278	L-Brush

* Not illustrated

**YFG255 SERIES RETHERMALIZERS
CHAPTER 2: PARTS LIST**

2.2 Cookpot Assemblies and Components

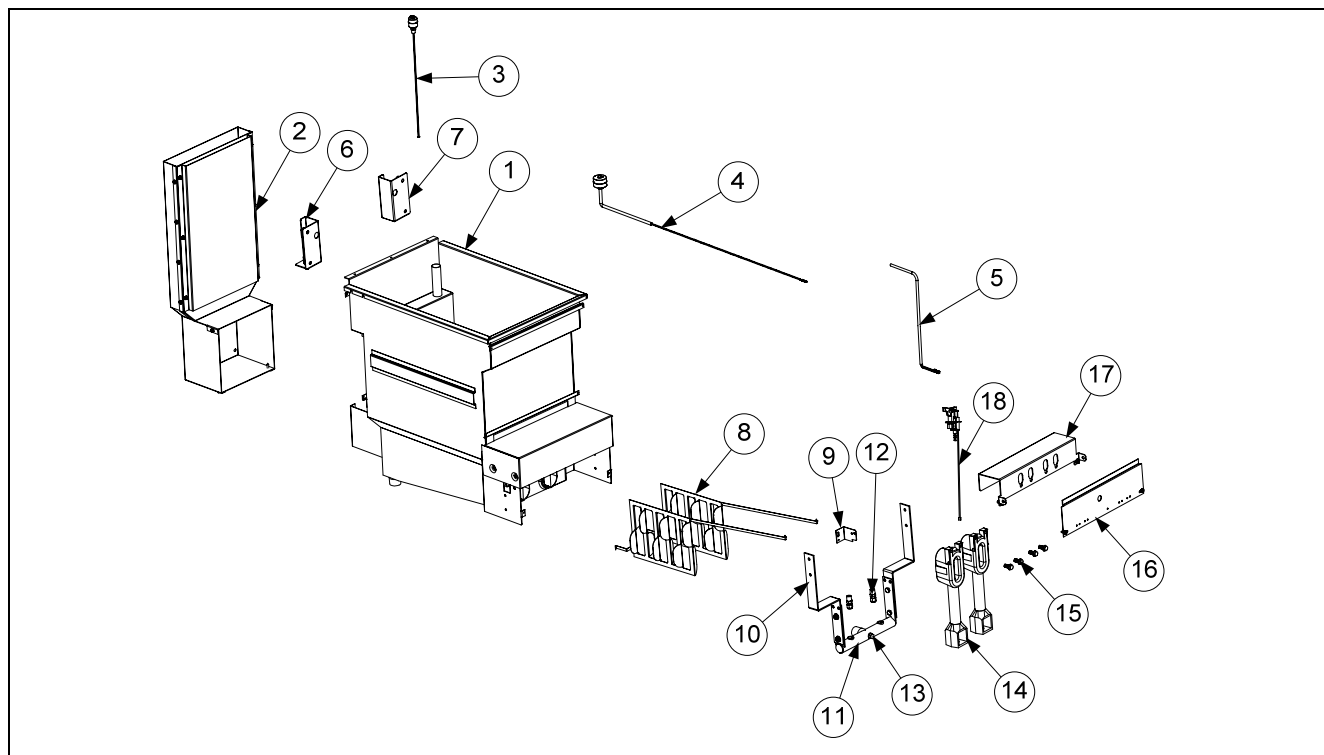

ITEM	PART #	COMPONENT
1	823-7641SP	Cookpot
2	108-0129	Flue Box Assembly
3	826-2622	Upper Float Switch (requires 813-0619)
*	813-0619	Flareless Male Tube Connection SS
4	108-0934	Lower Float Switch
*	826-2705	Snap Rings, Float Pkg. 5
5	826-2787	Probe, Temp with Controller (see item 6 on page 2-4)
*	810-3912	Fitting, Compression 1/4" NPT
6	231-8164	Support, Hinge Left
7	232-8164	Support, Hinge Right
8	230-6251	Baffle, Burner
9	230-6301	Bracket, Pilot Burner
10	824-2228	Support, Burner Manifold
11	810-3221	Manifold, Burner
12	810-2926	Orifice, Natural Gas (G20/25) 2.38mm (#42)
	810-2941	Orifice, Propane (G30/31) 1.51mm (#53)
13	813-0154	Plug 1/8" NPT
14	108-2612	Burner, Cast Iron with Clip Assy.
15	809-0459	Bolt, 5/16 -18 x 3/4
16	200-1330	Burner, Heat Shield
17	220-5955	Bracket, Burner Cast Iron
18	108-2481	Assembly, Pilot Natural Gas (<i>use 108-2614 for LP</i>)
*	807-1310	Flame Sensor
*	106-1238SP	Assembly, Ignitor Natural Gas (<i>use KIT6627 for LP</i>)

* Not illustrated

**YFG255 SERIES RETHERMALIZERS
CHAPTER 2: PARTS LIST**

2.3 Transformer Boxes and Control Frame Assemblies

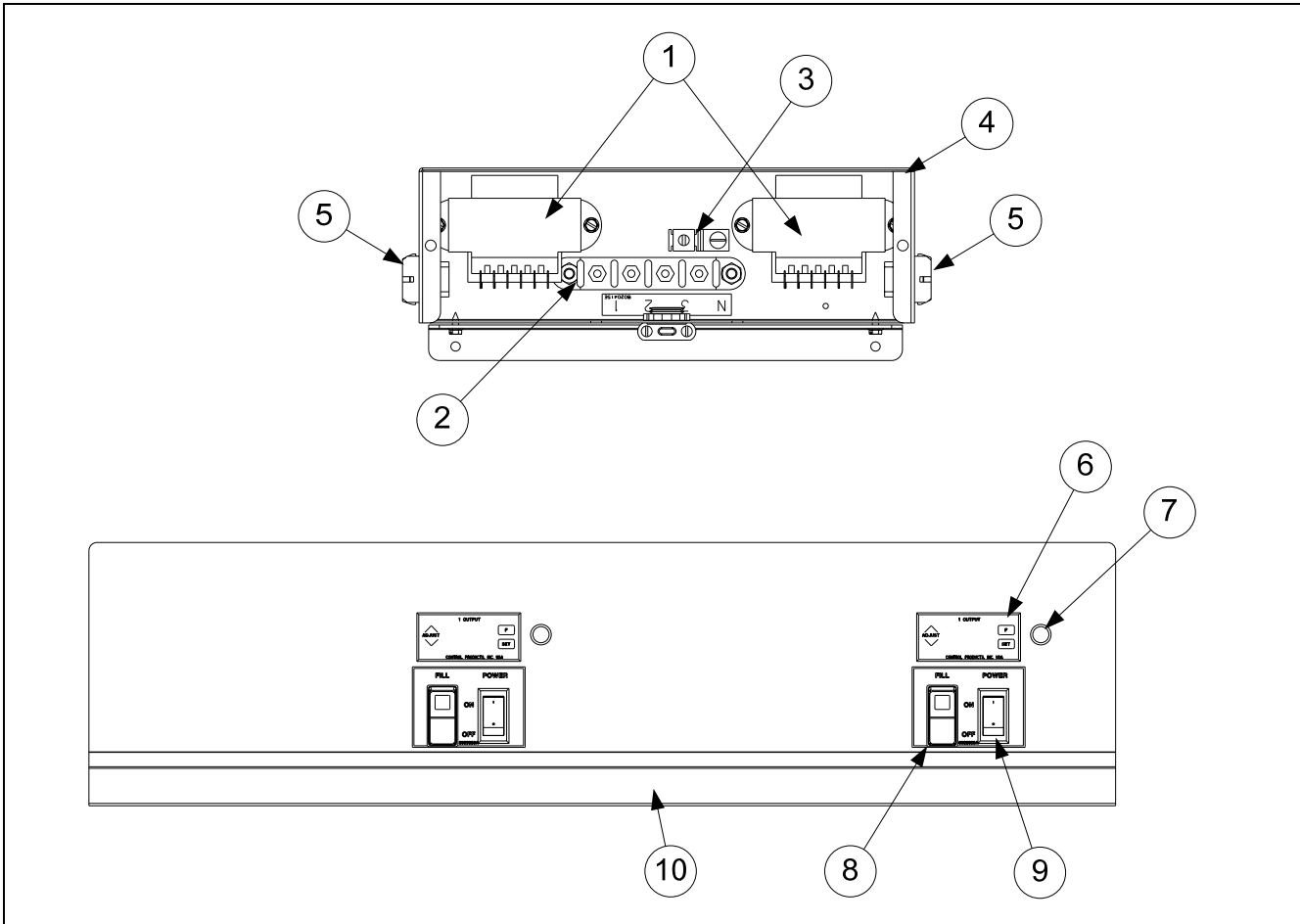

ITEM	PART #	COMPONENT
1	807-2176	Transformer, 100/120V 12/24VAC Dual Voltage
2	807-1973	Terminal, Post
3	807-0070	Terminal, Ground Lug
4	823-7781	Box, Transformer
*	220-7698	Cover, Transformer Box
5	108-0959	Assembly, Harness
6	826-2787	Controller, Digital with Probe and fitting
7	106-4729	Assembly, Green Indicator 24V Light
8	807-3576	Switch, Fill
9	807-4036	Switch, Power
10	230-8183	Fascia
*	108-2801	Harness Controller, Switch, Light
*	106-7649	Cordset 68"

* Not illustrated

**YFG255 SERIES RETHERMALIZERS
CHAPTER 2: PARTS LIST**

2.4 Harnesses

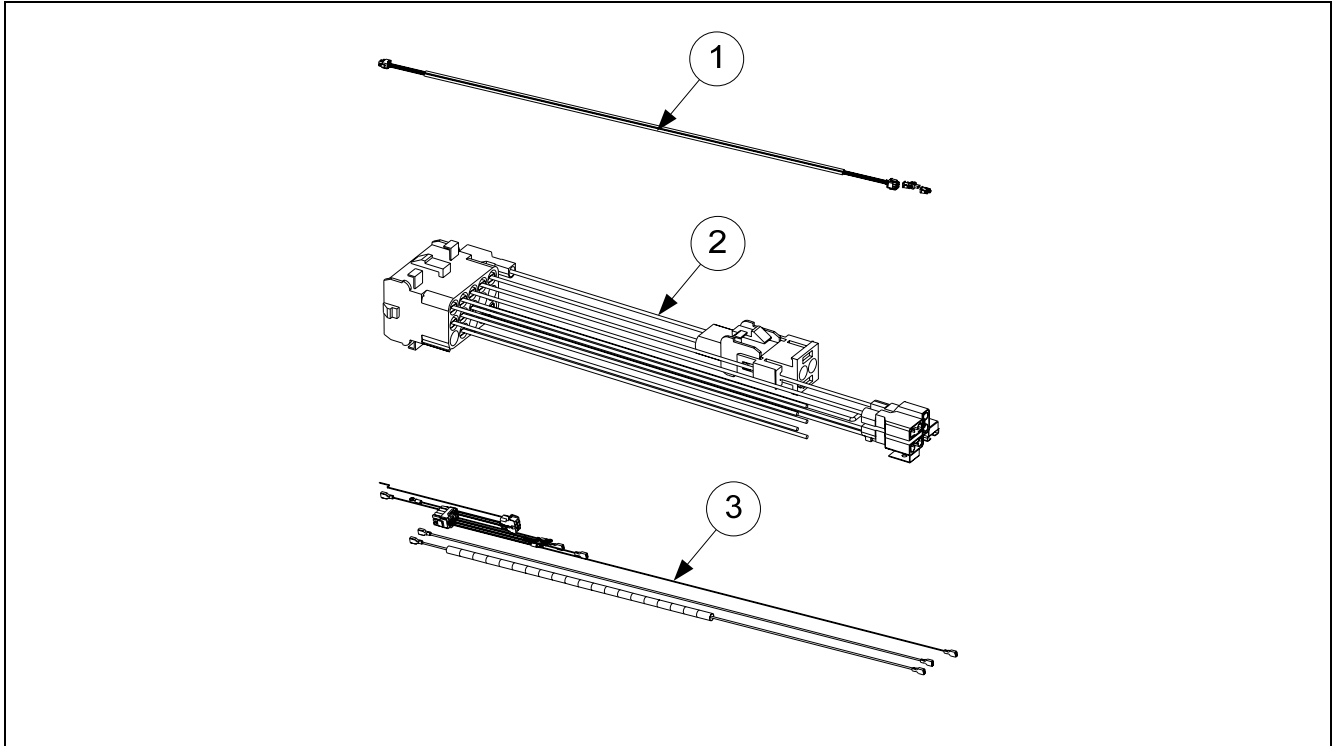

ITEM	PART #	COMPONENT
1	108-2800	Harness, Transformer, Solenoid and Float
2	108-2801	Harness, Controller, Switch and Light
3	108-2802	Harness, Ignition Module and Gas Valve

**YFG255 SERIES RETHERMALIZERS
CHAPTER 2: PARTS LIST**

2.5 Plumbing, Incoming Water

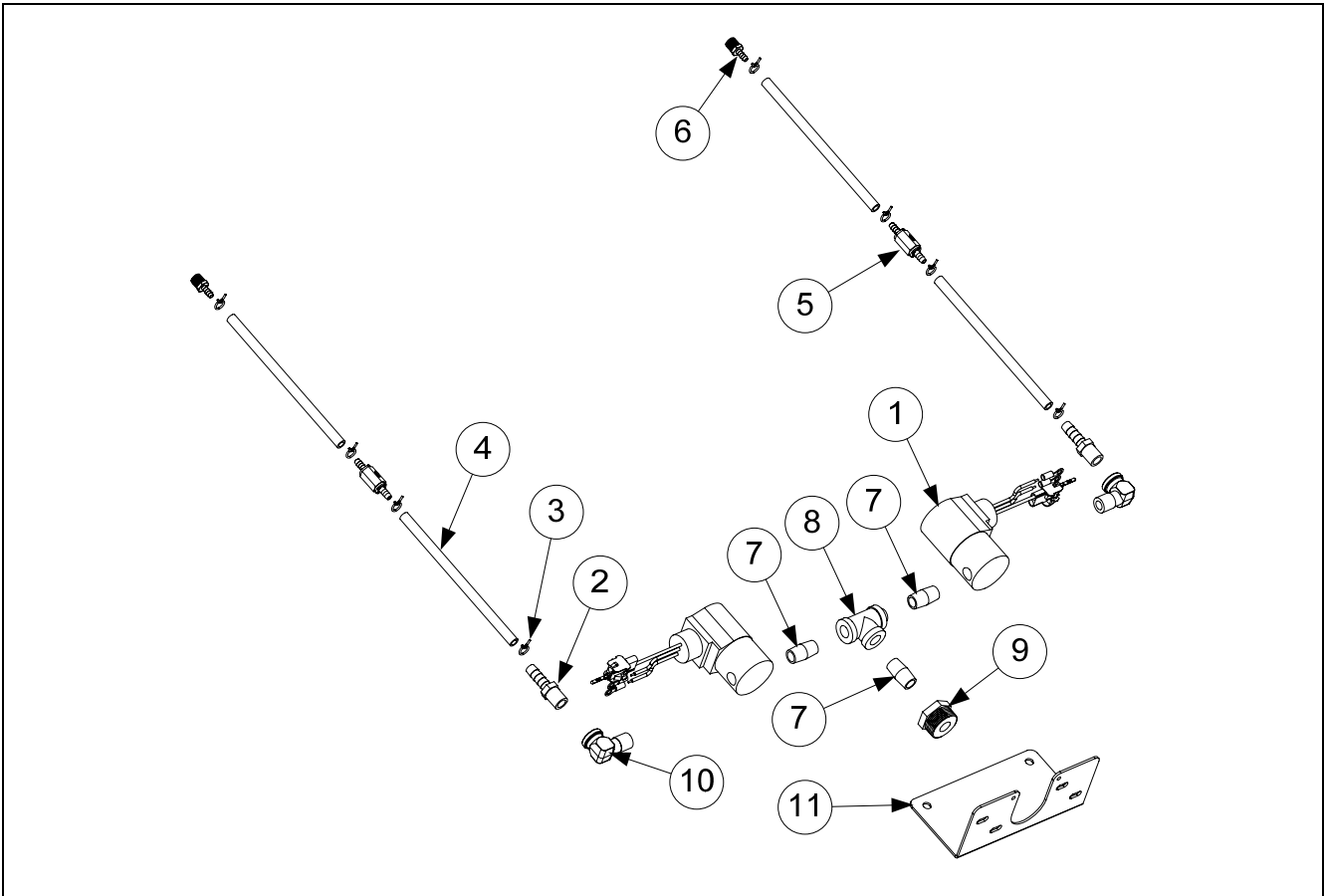

ITEM	PART #	COMPONENT
1	108-0933	Solenoid Valve Assembly
2	810-3199	Fitting, 1/4" NPT x 3/8" Tube Hose Barb
3	810-3244	Clamp, 5/8" Hose
4	811-1141	Tubing, Clear Plastic 3/8" ID (sold by the foot)
5	810-3243	Valve, In-line Check
6	810-3258	Adaptor, 3/8" Barb x 1/2" NPT Brass
7	813-0582	Nipple, 1/4" NPT Close Brass
8	813-0449	Tee, 1/4" NPT Brass
9	810-3573	Adaptor, Pipe to Hose 1/4" NPT x 3/4"
10	813-0502	Elbow, 90° Street NPT Brass
11	220-6016	Mount Solenoid

**YFG255 SERIES RETHERMALIZERS
CHAPTER 2: PARTS LIST**

2.6 Plumbing, Drain

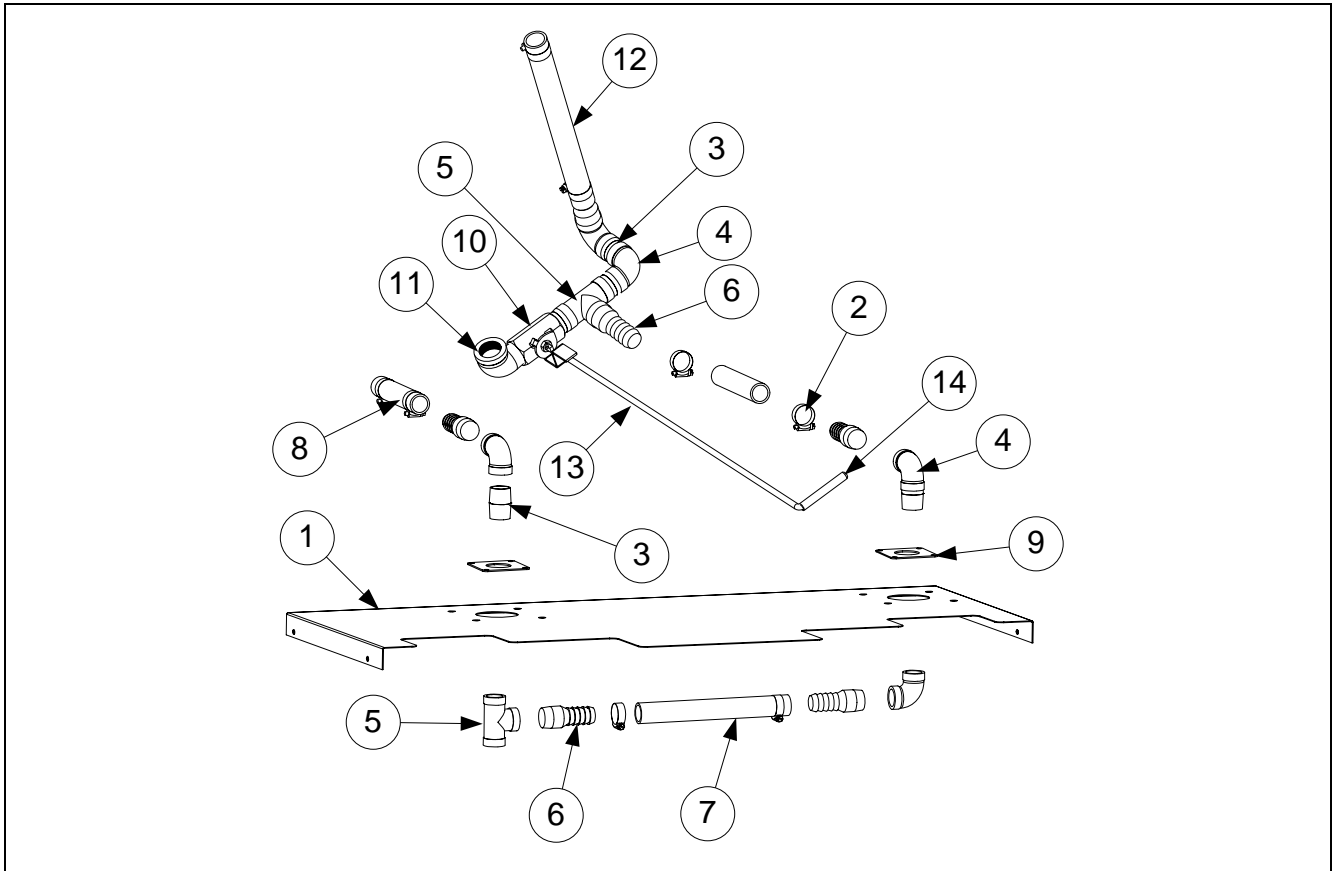

ITEM	PART #	COMPONENT
1	220-8186	Shield, Vapor Front
2	809-0374	Clamp, Hose
3	813-0138	Nipple
4	813-0202	Elbow, 90° 1"
5	813-0314	Tee, 1"
6	813-0525	Barb Fitting, 1" Pipe to Hose
7	816-0779	Hose, Drain 10.25"
8	816-0787	Hose, Drain 6.75"
9	823-7649	Plate Assembly
10	810-3569	Valve, Drain Brass 1" NPT
11	813-0266	Elbow, Street 1" NPT
12	816-0910	Hose, Drain 12.50"
13	823-6279	Handle, Drain Valve
14	816-0639	Cap, Vinyl Red

**YFG255 SERIES RETHERMALIZERS
CHAPTER 2: PARTS LIST**

2.7 Plumbing, Gas Manifold

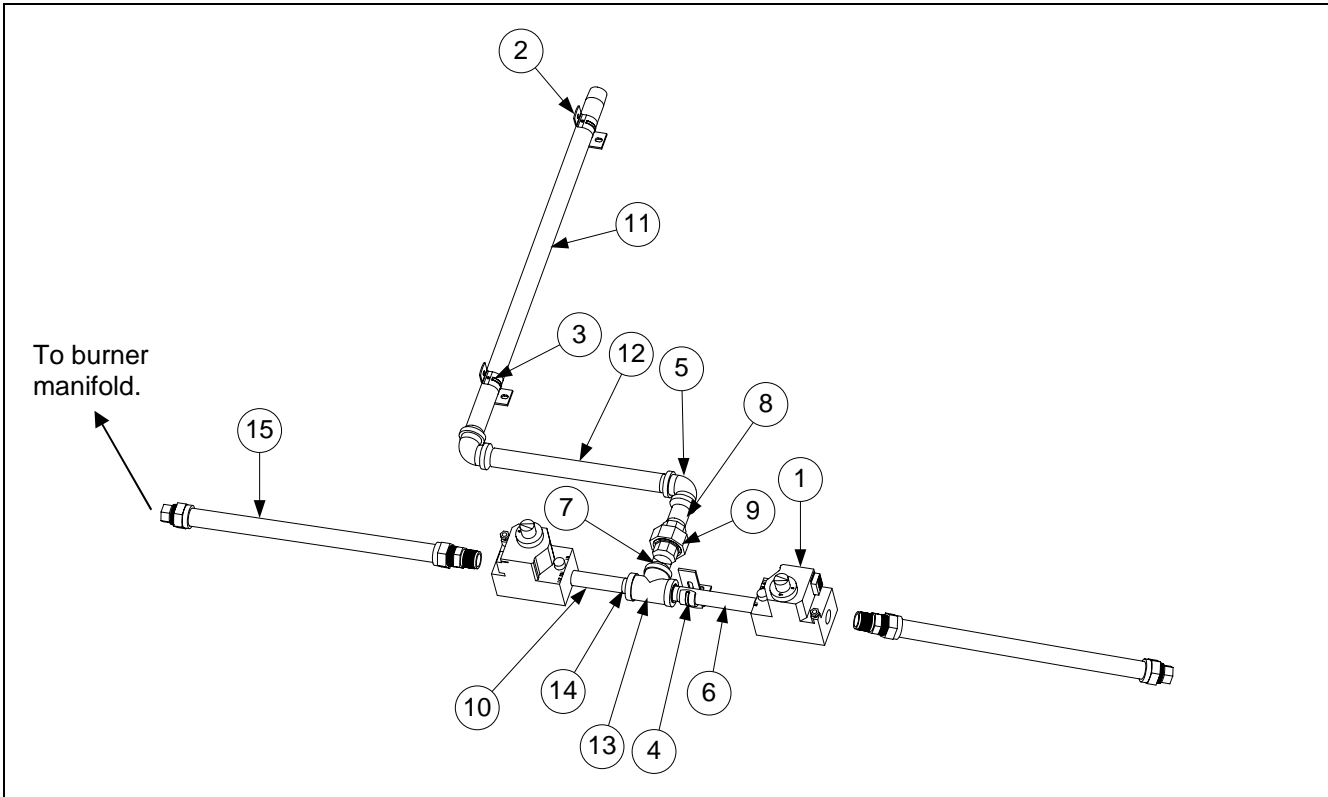

ITEM	PART #	COMPONENT
1	807-3552	Valve, Gas Natural 24V Honeywell
	807-3628	Valve, Gas Propane 24V Honeywell
2	200-1450	Bracket, Gas Valve Support
3	810-2808	Clamp, 3/4"
4	810-3722	Clamp, 1/2" Pipe Heavy
5	813-0066	Elbow, 3/4" NPT 90°
6	813-0096	Nipple, 1/2" x 6.00" NPT
7	813-0112	Nipple, 3/4" x 2.00" NPT
8	813-0114	Nipple, 3/4" x 2.50 NPT
9	813-0174	Union, 3/4" NPT
10	813-0251	Nipple, 1/2" x 4.50 NPT
11	813-0257	Nipple, 3/4" x 24.50" NPT
12	813-0382	Nipple, 3/4" x 11.50" NPT
13	813-0387	Tee, 3/4" NPT
14	813-0763	Bushing, 3/4" x 1/2" ID NPT
15	810-2542	Flexline, 3/4" NPT x 18.50"
*	810-0703	Gas Line 1/4" x 20.00" (Gas Valve to Pilot Assy.)
*	810-0691	Vent Tube
*	810-2734	Gas Line, 3/4" x 48.00" with Quick Disconnect

* Not illustrated

**YFG255 SERIES RETHERMALIZERS
CHAPTER 2: PARTS LIST**

2.8 Fasteners

ITEM	PART #	COMPONENT
*	809-0428	Bolt, ¼-inch – 20 x ½-inch Hex Head ZP Tap
*	809-0429	Bolt, ¼-inch – 20 x 2.00-inch Hex Head ZP Tap
*	809-0514	Capscrew, 5/16-inch-18 NC Hex
*	809-0448	Clip, Tinnerman
*	826-1366	Nut, 4-40 Keps Hex (Pkg. of 25) (809-0237)
*	826-1358	Nut, 6-32 Keps Hex (Pkg. of 25) (809-0049)
*	809-0247	Nut, 8-32 Keps Hex
*	826-1376	Nut, 10-32 Keps Hex (Pkg. of 10) (809-0256)
*	809-0766	Nut, 10-32 Keps Hex SS
*	809-0581	Nut, ½ NPT Locking
*	809-0020	Nut Cap 10-24 NP
*	826-1372	Nut Grip ¼-inch 1/4-20 Hex NP (Pkg. of 10) (809-0059)
*	809-0417	Nut Flange ¼-inch 1/4-20 Serr
*	809-0535	Nut, "T" ¼-inch-20 x 7/16 SS
*	826-1389	Nut, Nylock ¼-inch-20 (Pkg. of 10) (809-0803)
*	809-0540	Nut, Lock ½-inch-13 Hex 2-Way ZP
*	813-0154	Plug, Pipe ⅛-inch Brass, Hex Head
*	826-1359	Screw, 4-40 x ¾-inch Slotted Round Head (Pkg. of 25) (809-0354)
*	826-1365	Screw, 6-32 x ⅜-inch Slot Head (Pkg. of 25) (809-0095)
*	809-0357	Screw, 6 x ⅜-inch Phillips Head NP
*	809-0359	Screw, 8 x ¼-inch Hex Washer Head
*	809-0360	Screw, 8 x ⅜-inch Hex Washer Slot Head
*	826-1371	Screw, 8 x ½-inch Hex Head ZP (Pkg. of 25) (809-0361)
*	809-0818	Screw, 8 x ½-inch Type B
*	809-0364	Screw, 8 x ⅝-inch Hex Washer Head ZP
*	809-0518	Screw, 8-32 x ⅜-inch Hex Washer Slotted Head SS
*	809-0104	Screw, 8-32 x ½-inch Slotted Head ZP
*	826-1363	Screw, 8-32 x ½-inch NP (Pkg. of 25) (809-0103)
*	826-1360	Screw, 10-24 x 5/16-inch Round Slot Head ZP (Pkg. of 25) (809-0024)
*	826-1330	Screw, 10-32 x ⅜-inch Slot Head SS (809-0117)
*	809-1003	Screw, 10-32 x ⅜-inch Hex Trim Head SS
*	826-1375	Screw, 10-32 x ¾-inch Hex Trim Head SS (Pkg. of 5) (809-0401)
*	809-1000	Screw, 10-32 x 1¼-inch Hex Sck C/S
*	826-1374	Screw, 10 x ½-inch Hex Head (Pkg. of 25) (809-0412)
*	809-0266	Screw, 10 x ½-inch Phillips Head ZP
*	809-0434	Screw, 10 x ⅜-inch Hex Washer Head NP
*	809-0123	Screw, 10 x ¾-inch Slot Head
*	826-1389	Screw, 1/4-20 x ¾-inch Hex Head ZP (Pkg. of 10) (809-0131)
*	809-0582	Washer ½ NPT Locking
*	809-0184	Washer, #10 LK ZP
*	809-0190	Washer, .625 X .275 X 40 Flat SS
*	809-0191	Washer, Lock 1/4 Spring ZP
*	809-0193	Washer, Flat 1/4 Nylon
*	809-0194	Washer, Flat 5/16 ZP

THIS PAGE INTENTIONALLY LEFT BLANK



Frymaster, L.L.C., 8700 Line Avenue, Shreveport, Louisiana 71106

TEL 1-318-865-1711

FAX (Parts) 1-318-688-2200

FAX (Tech Support) 1-318-219-7135

PRINTED IN THE UNITED STATES

SERVICE HOTLINE
1-800-551-8633

819-6900
SEPTEMBER 2011